

# Fissile Material Detection

3

## Development of Sealed Neutron Generator for Fissile Material Detection

Mayank Shukla\*, Prashant Singh, Yogesh Kashyap, Tushar Roy, Shefali Shukla, Baribaddala Ravi, M. R. More and L. M. Pant

Technical Physics Division, Bhabha Atomic Research Centre, Mumbai – 400085, INDIA

S. K. Raut, S. G. Sawant, Ram Avtar Jat and S. C. Parida

Product Development Division, Bhabha Atomic Research Centre, Mumbai – 400085, INDIA

N. K. Prasad and M. G. Bagalkar

Electromagnetic Application and Instrumentation Division, Bhabha Atomic Research Centre, Mumbai – 400085, INDIA

S. M. Yusuf

Physics Group, Bhabha Atomic Research Centre, Mumbai – 400085, INDIA

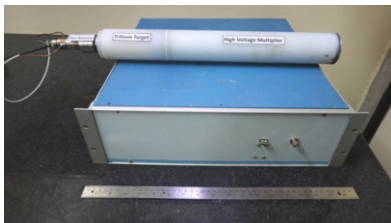

Sealed neutron generator with control electronics inside 19-inch box

### ABSTRACT

We present indigenous development of DC accelerator based 14MeV Deuterium(D)-Tritium(T) compact sealed neutron generator for laboratory and field applications. It comprises of a sealed tube with a Penning Ion Source (PIS), metallic D-gas reservoir, beam shaping & accelerating shroud and tritium target holder in-housed in an all metal-to-ceramic joints compact mechanical housing. A micro controlled high current power supply is used to ionize deuterium gas in the ion source. The PIS is operated in pulsed mode with pulse duration ranging from of 100 $\mu$ s to 500 $\mu$ s and up to 1 kHz repetition rate. To produce fusion neutrons, a deuterium ion beam is extracted through an aperture, accelerated to 90kV, and focused on a Tritium target. The ion source and DC acceleration are powered by micro-controlled indigenously built gate pulse generators and high voltage power supply that are controlled by a remote computer using graphical user interface software. The generator gives a neutron yield of  $\sim 8 \times 10^6$  n/s at 80kV with 200 $\mu$ s pulse ON time and 500 Hz repetition rate. It has been used for fissile material detection using prompt fission neutron activation.

KEYWORDS: Penning ion source, Deuterium, Tritium, Neutron yield, Sealed neutron generator

### Introduction

Compact sealed neutron generators with moderate neutron yield ( $10^6$  to  $10^7$  n/s) find field applications such as mining exploration, oil well logging, coal analysis for power plants etc. These generators, being more handy, also finds use in areas such as detection of special nuclear materials, explosive detection, narcotics detection, material characterization [1-8]. The DC accelerator-based compact sealed generator mainly comprise of an ion source, a D-gas reservoir, acceleration electrode and neutron-producing target. In these generators, a D-D (2.45 MeV) / D-T (14.1 MeV) fusion reaction occurs when an accelerated deuterium ion beam interacts with the target (D or T), producing mono energetic neutrons. The design & development of an indigenous sealed neutron generator is presented in the following sections. Compact micro controlled 3kV high voltage ion source pulsed power supply, 90kV high voltage DC acceleration power supply, constant current (variable upto 8A) gas reservoir heating power supply along with GUI software to control the neutron generator through a remote PC have been designed and developed. In pulsed mode operation with 200 $\mu$ s pulse duration and 500Hz repetition rate, the neutron generator produces 14.1 MeV neutrons with neutron yield  $\sim 8 \times 10^6$  n/s at 80kV acceleration voltage. The generator has been tested for fissile material detection using prompt fission neutron activation. Approximately 3gm and 5gm  $^{235}\text{U}$  has been detected in 1000 kg of quartz sand kept in a plastic drum.

### Sealed Neutron Generator

As shown in Fig.1, the compact sealed neutron tube is made up of a penning ion source (PIS), a metallic titanium D-gas getter reservoir, a beam shaping and accelerating shroud electrode, and a tritium target holder, which are assembled in a small mechanical assembly with ceramic-to-metal sealing joints. The mechanical assembly is evacuated to ultra-high vacuum ( $\sim 10^{-8}$  mbar) through the highly malleable brazed copper tubes. A multi-pin electrical feedthrough provides electrical contacts to anode & cathode of PIS and to gas reservoir metallic getter strips. All metallic joints combining the ion source, high voltage ceramic spacer, shroud electrode and target holder were precision welded under inert gas atmosphere to achieve a leak rate of  $< 10^{-12}$  mbar litre/s. The neutron tube was detached from the vacuum system using a pinch-off tool.

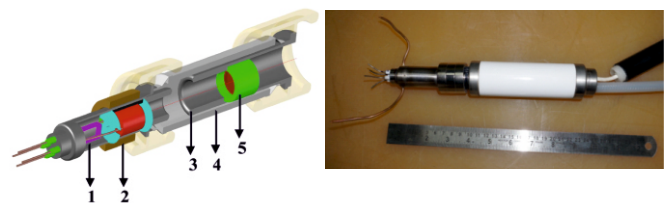

Fig.1: Schematic and assembled sealed neutron tube - 1. Metallic getter strip; 2. PIS; 3. Shroud Electrode; 4. HV Ceramic Spacer and 5. Tritium Target Holder.

\*Author for Correspondence: Mayank Shukla  
E-mail: mayank@barc.gov.in

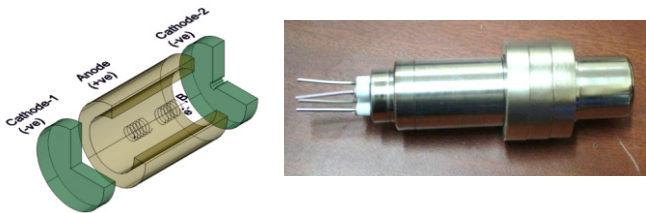

Fig.2: Cold cathode penning Ion Source.



Fig.3: Deuterium loaded metallic titanium getter strips.



Fig.4: Spot-weld getter strips on feedthrough.

**Penning Ion Source**

The discharge in the cold cathode Penning ion source is described as a weakly ionized plasma created utilizing DC voltage in a low magnetic field and low gas pressure. A hollow cylindrical anode positioned between two parallel cathode plates in a constant axial magnetic field creates a symmetrical geometry that serves as the penning discharge chamber, as illustrated in Fig.2. A useful ion beam can be retrieved through an aperture in one of the cathode plates. Low sputtering materials in the plasma environment such as high purity titanium for anode and thin tantalum (0.1mm thick) for cathode were chosen for stable operation of the ion source.

**Deuterium Gas Reservoir Getter and Neutron Target**

Metallic gas reservoir getter is required for controlled release of deuterium gas into the ion source in sealed neutron tube. Titanium metal of Grade-1 in the form of thin strip (40mm x 6mm x 0.1mm thick) was used as gas storage material. Two such strips were evacuated to ultra-high vacuum (UHV) and heated to 500°C activation temperature inside a UHV gas handling manifold. The UHV system consists of reaction vessel, pre-calibrated volumes, pressure and vacuum gauges and turbo molecular pumping station. In order to adsorb a known amount of deuterium gas, activated strips were exposed to the gas at about 200°C. The pressure-volume relationship was used to compute the deuterium content in the titanium while monitoring the system pressure. The final composition of the TiD<sub>x</sub> phase was calculated to be x~0.7 from the final pressure of the system. This corresponds to ~ 130cc of deuterium gas adsorbed in the two titanium strips. Fig.3 shows the physical appearance of the strips loaded with deuterium. These strips

were spot-welded on the feedthrough pins for controlled release of gas in the plasma chamber of the ion source using DC power supply of 6-8A as shown in Fig.4. The assembled ion source with metallic getter (Fig.2) was tested for gas sorption/desorption and discharge inside an all-metallic leak tight UHV system under static vacuum conditions up to pressure of the order of 10<sup>-2</sup> mbar.

A high purity grade-1 Ti thin film (~3µm) deposited on an OFHC copper disk (16mm diameter and 0.8mm thick) using chemical vapor deposition was used to fabricate tritium neutron target used in the tube [9]. The target was fabricated using a similar UHV gas manifold as described above with glove box. Tritium loading in the Ti film was carried after activating the film up to 500°C under high vacuum [10]. An ~3 Ci (±10%) tritium target on copper disk was fixed on the target holder electrode as shown in Fig.1.

**High Voltage Power Supplies and Control Electronics**

As illustrated in Fig.5, the sealed neutron tube requires following power supplies for operation: a 3kV pulsed power supply for ion source, a 100kV high voltage DC acceleration power supply, and a constant current (varying up to 8A) getter heating power supply. The compact ion source (3kV/20mA) and DC acceleration (100kV/2mA) power supplies were designed and developed using inverter followed by rectifier/multiplier to achieve the required voltages. The block diagram of the inverter is shown in Fig.6. Ion source power supply was used to bias a MOSFET based gate pulse generator for pulsed operation of 200µs pulse duration and 500Hz repetition rate.

A Cockcroft-Walton high voltage multiplier allows for high voltage DC acceleration up to -100kV. The shroud electrode

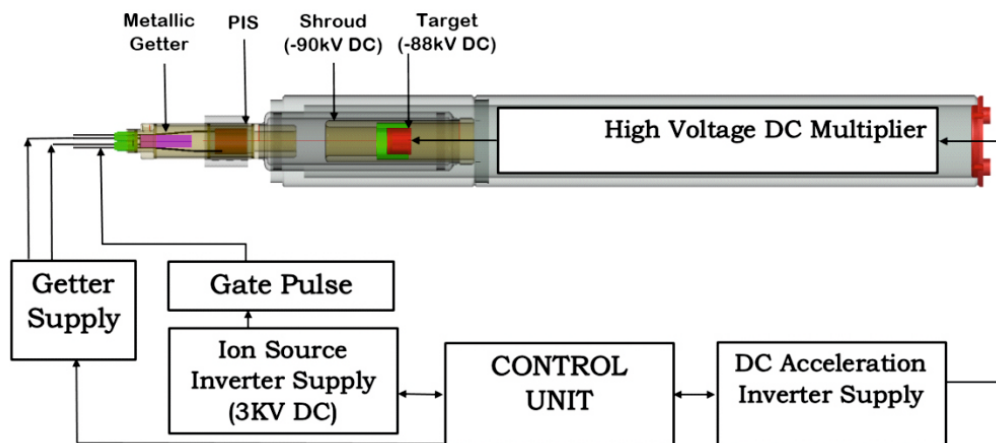

Fig.5: Block diagram of Neutron Generator.

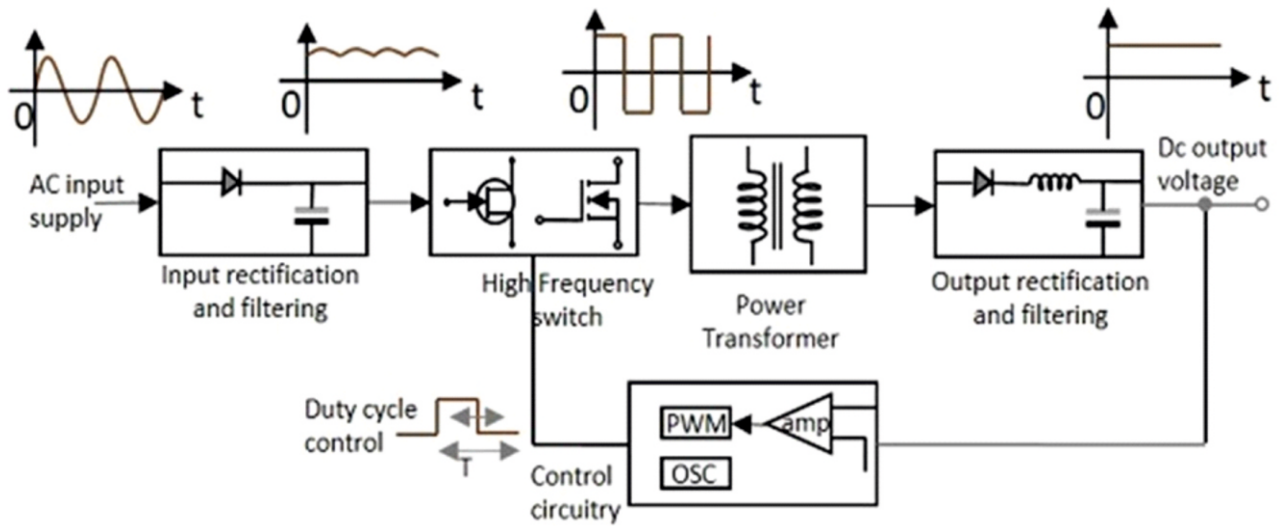

Fig.6: Inverter block diagram.

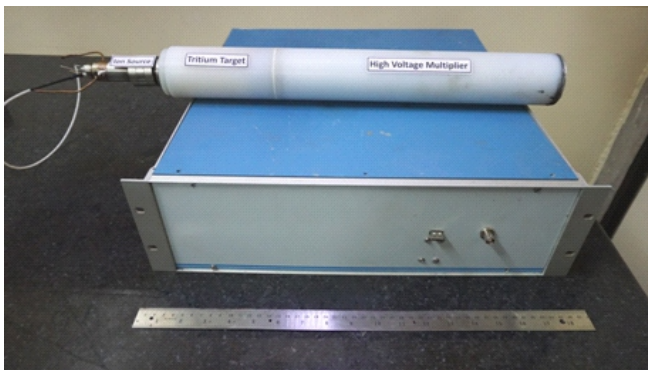

Fig.7: Sealed neutron generator with control electronics inside 19-inch box.

biased slightly positive with respect to the target electrode voltage between the shroud electrode and the target electrode prevents secondary electron back current from entering the ion source, ensuring steady neutron tube operation. The high voltage multiplier in combination with set of reversed biased Zener diodes generates -88KV DC for shroud electrode and -90KV DC for target. This multiplier section is insulated inside a cylindrical nylon assembly filled with high voltage insulation oil that also serves as coolant for the neutron target. The entire electronics along with the microcontroller -based control circuits have been incorporated in a 19-inch box. The neutron source along with the electronic control box is shown in Fig.7. GUI software to control the neutron generator through a remote PC has also been developed as shown in Fig.8.

### Testing of Neutron Generator

Sealed neutron generator was tested using the indigenously developed electronics. For pulsed operation, PIS have been biased up to ~3KV voltage and pulse duration

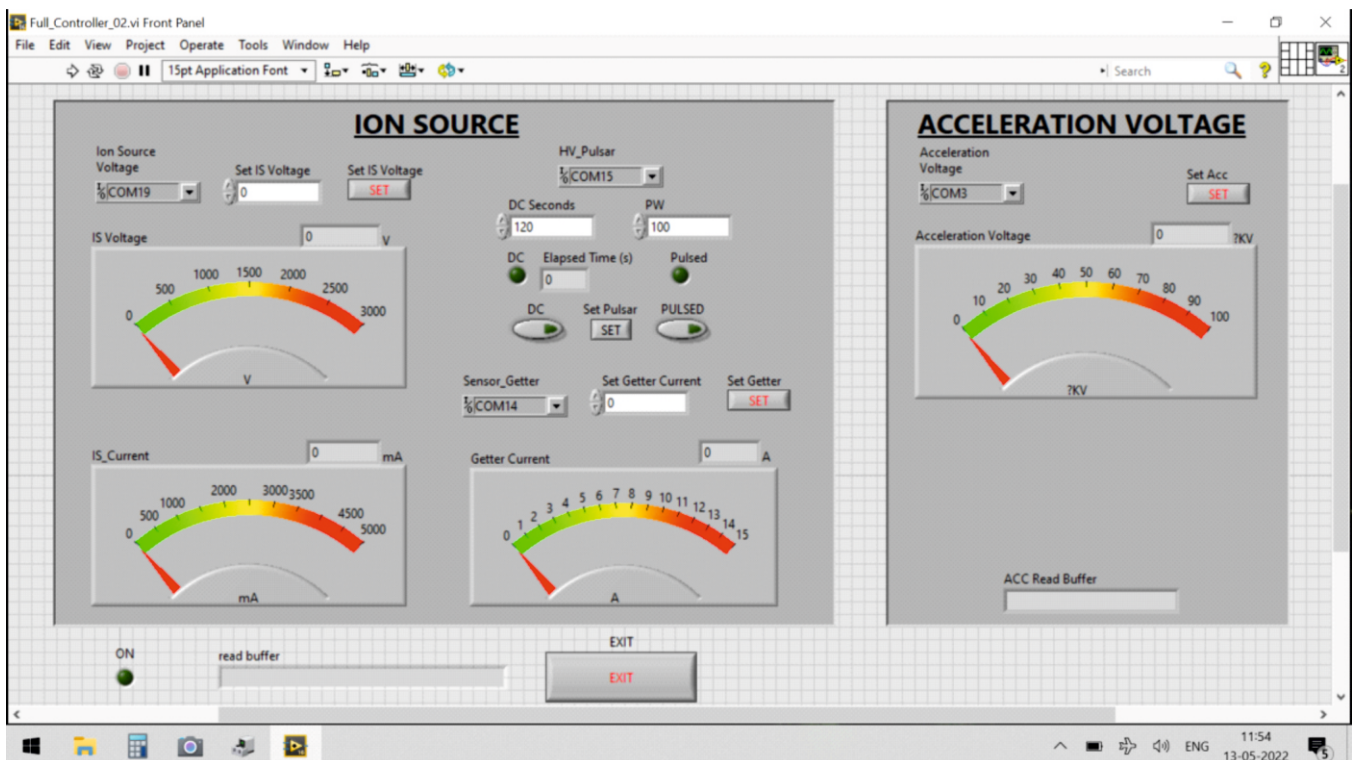

Fig.8: GUI control of sealed neutron generator.

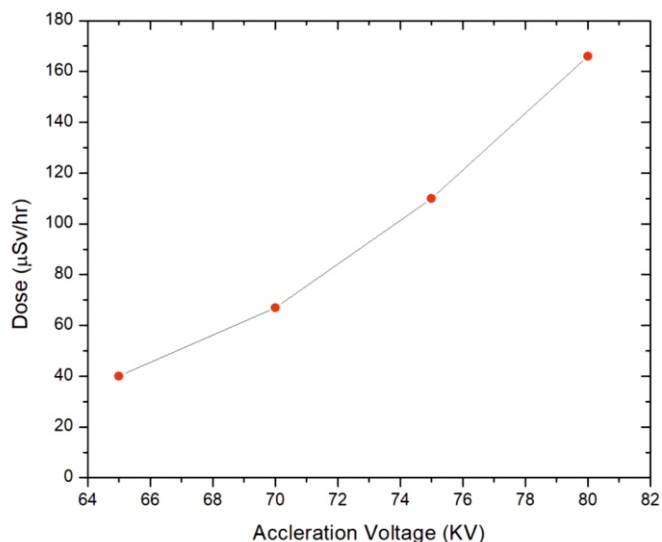

Fig.9: Measured neutron dose vs acceleration Voltage.

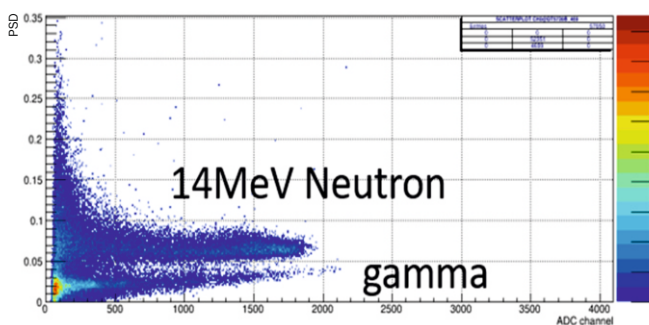

Fig.10: Neutron Energy measurement using liquid scintillator detector.

~200µs with a repetition rate of 500Hz. The high voltage DC acceleration has been varied up to 80kV. The measured neutron dose as a function of acceleration voltage for typical operation is shown in Fig.9. Neutron yield  $\sim 8 \times 10^6$  n/s was estimated by counting number of bubbles using bubble detector, detector sensitivity and dose equivalent for D-T (14.1MeV) neutrons [11]. Fig.10 & Fig.11 show the 2-D PSD measurement of 14.1 MeV neutrons using liquid scintillator detector and neutron spectra recorded using neutron spectrometer, respectively.

### Fissile material detection using sealed neutron generator

The indigenously developed sealed neutron generator has been used for the detection of fissile material using prompt fission neutron activation. Approximately 1000kg of quartz sand was filled in a plastic drum of 1meter diameter having centrally located cavities to insert neutron generator and He-3 detector. The neutron generator was operated in repetitive mode with 200µs pulse duration and 500Hz repetition frequency giving a neutron yield of  $\sim 8 \times 10^6$  n/s. Fig.12 show the signals recorded for 3gm and 5gm of uranium disk placed in the sand with respect to the background signal from the sand.

### Conclusion

Compact DC acceleration based sealed D-T neutron generator producing 14.1 MeV high energy neutrons has been designed and developed indigenously. This generator is useful for both field as well as applications that demand low probing volume and moderate neutron yield ( $\sim 10^7$  n/s). The sub-assemblies of the generator, such as the penning ion source, deuterium gas reservoir, acceleration, and target electrodes,

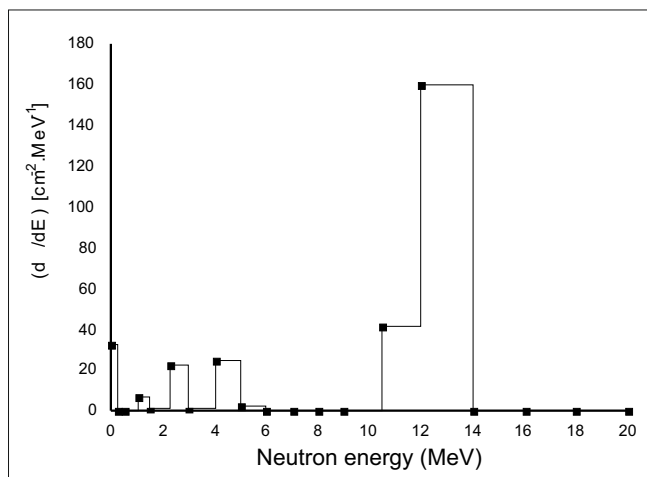

Fig.11: Neutron spectra of D-T generator kept on HDPE block using neutron spectrometer.

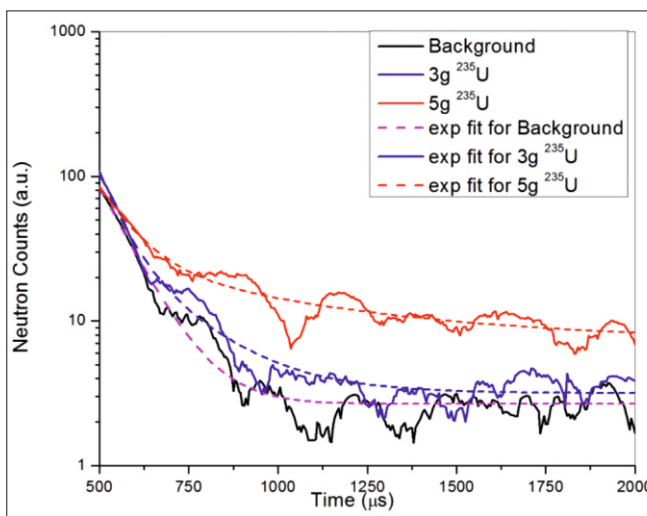

Fig.12: Experimental plots for 3gm and 5gm <sup>235</sup>U in 1000kg of quartz sand.

have been designed and developed in-house, precision welded, and pinched off to make a compact sealed neutron tube. Micro controlled high voltage ion source & DC acceleration power supplies, gate pulse generator, gas reservoir heating supply have also been designed and developed indigenously. The generator is being operated by remote computer using graphical user interface software. The generator gave a neutron yield of  $\sim 8 \times 10^6$  n/s at 80kV with 200µs pulse ON time and 500 Hz repetition rate. This generator has been successfully used for fissile material detection in laboratory using prompt fission neutron activation. It is being modified for making a PFN logging probe for field applications such as detection of uranium in a borehole.

### Contributions

The Neutron and Synchrotron Physics Section (N&SRPS), TPD has conceptualized, designed and developed the compact sealed neutron generator that includes penning ion source, high voltage DC acceleration and target electrodes, deuterium gas reservoir, high voltage and other control electronics along with GUI software etc.

Process Development Division has contributed in loading of deuterium gas in Ti metal strips and tritium in Ti film on copper substrate.

Mechanical Fabrication Section, EmA&ID has contributed in fabrication of mechanical components for ion source and high voltage housing and low temperature pulse TIG welding of the metallic joints.

### Acknowledgements

Authors are thankful to S. Kannan, Director, RC&I Group, BARC for his support and encouragement. We are also thankful to S. K. Malhotra, Head, EmA&ID, BARC for his continuous support. Special thanks to R. P. Kushwaha and Santosh Kumar, Material Joining Section, Materials Science Division, BARC for precision laser welding of the multi-pin feedthrough of the penning ion source and N. A. Nalawde, EMAS, EmA&ID for EDM wire cutting of feedthrough pins. We acknowledge the support provided by NP&HIAS, NPD and X&NTS, TPD for neutron energy measurement using liquid scintillator detector. RSS, RSSD is also acknowledged for their support in measurement of neutron spectra of the D-T neutron generator.

### References

- [1] "Neutron Generators for Analytical Purposes", IAEA Radiation Technology Reports Series No. 1, 2012.
- [2] J. Reijonen, E. O. Lawrence, Compact Neutron Generators for Medical, Home Land, Security and Planetary Exploration, Proc. Particle Accelerator Conference, Knoxville, Tennessee, 2005.
- [3] Y. Wu, Development of a Compact Neutron Generator to be Used for Associated Particle Imaging using a RF-Driven Ion Source, Ph.D. thesis, University of California, Berkeley, 2009.
- [4] E. S. Grishnyaev, Development of miniature neutron generators for science and well logging, 4<sup>th</sup> Asian Forum for Accelerators and Detectors (AFAD-2013), February 25-26, 2013, Novosibirsk, Russia.
- [5] Alvarez, R. A., Dougan, A. D., Rowland, M. R., Wang T. F., Neutron Interrogation to Identify Chemical Elements with an Ion-Tube Neutron Source, J. Radioanal. Nucl. Chem., 1995, 192, 73–80.
- [6] P. C. Womble, F. J. Schultz, G. Vourvopoulos, Non-Destructive Characterization using Pulsed Fast-Thermal Neutrons, Nucl. Instrum. Methods Physics Res. B, 1995, 99, 757–760.
- [7] T. Gozani, D. Strellis, Advances in Neutron Based Bulk Explosive Detection, Nucl. Instrum. Methods Physics Res. B, 2007, 261, 1-2, 311-315.
- [8] Y. Kashyap, A. Agrawal, T. Roy, P. S. Sarkar, M. Shukla, T. Patel, A. Sinha, Differential Die Away Analysis for detection of <sup>235</sup>U in a metallic matrix, Nucl. Instrum. Methods Physics Res. A, 2016, 806B, 1-4.
- [9] Mayank Shukla, Niranjana Ramgir, Baribaddala Ravi, Prashant Singh, K. R. Sinju, A. K. Debnath, K. P. Muthe, Yogesh Kashyap, Tushar Roy, Shefali Shukla, Mahendra More, K. G. Bhushan, K. C. Rao, S. G. Sawant, Ram Avtar Jat, S. K. Raut, S. C. Parida, S. C. Gadkari and T.V. Chandrasekhar Rao, Indigenous Development of Neutron Producing Targets for DC Accelerator based Neutron Generators, BARC Internal Report, BARC/2020/1/006.
- [10] Mayank Shukla, Niranjana Ramgir, Prashant Singh, Yogesh Kashyap, A. K. Debnath, K. P. Muthe, Tushar Roy, Baribaddala Ravi, Shefali Shukla, S. G. Sawant, S. K. Raut, Ram Avtar Jat, S. C. Parida, K. G. Bhushan and K. C. Rao, Titanium Hydride targets for Portable Neutron Generator applications, 2020, BARC Newsletter, 370.
- [11] Impact of Switching to the ICRP-74, Neutron Flux-to-Dose Equivalent Rate Conversion Factors at the Sandia National Laboratory Building 818 Neutron Source Range, Sandia Report, D. C. Ward, Sandia National Laboratories, Albuquerque, N. Mex., USA, SAND 2009, 1144.